



"Nothing works SMARTER for you than US!"

MegaTop Salad Prep Refrigerator

Shelving:

- One (1) heavy duty, PET Coated shelf per section
- 1" adjustable shelving heights



Refrigeration System:

- Oversized and balanced factory system using CFC Free R134a or R404a refrigerant. This includes a highly efficient evaporator and condenser for greater efficiency and faster recovery



USSM-60-24

Castors:

- 5" Heavy Duty, Locking Front



Doors:

- Stainless steel exterior and stainless interior
- Snap in magnetic door gaskets of one piece construction removable without tools for ease of cleaning and replacement
- Door bumpers prolong gasket life
- Tension assisted self-closing doors



Electrical:

- Connection: 115/60/1 PH, 20 amp dedicated outlet



115/60/1
NEMA-5-20R

Cabinet Construction:

- Exterior - Stainless steel front, doors & bottom
- Interior - NSF approved Stainless steel
- Pans included; 24 pc @1/6th size
- Installed 9 ft power cord
- High density cutting board included

Insulation :

- Entire cabinet structure and doors insulated using foamed-in-place CFC free polyurethane foam

Temperature Control :

- Easy access temperature control



Refrigerator Holds 32° F to 45° F for the Best in Food Preservation

www.US-Refrig.com



USSM-60-24

(888) 556-2112

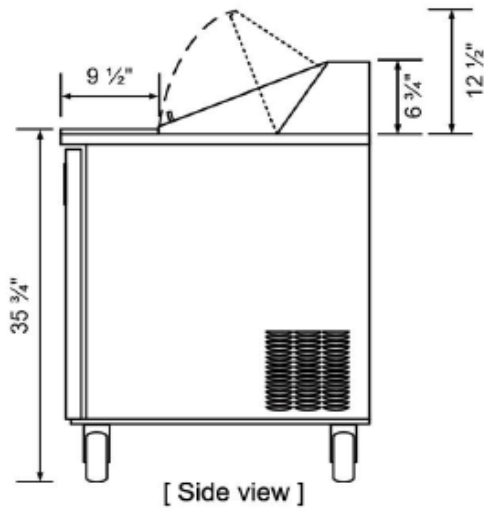
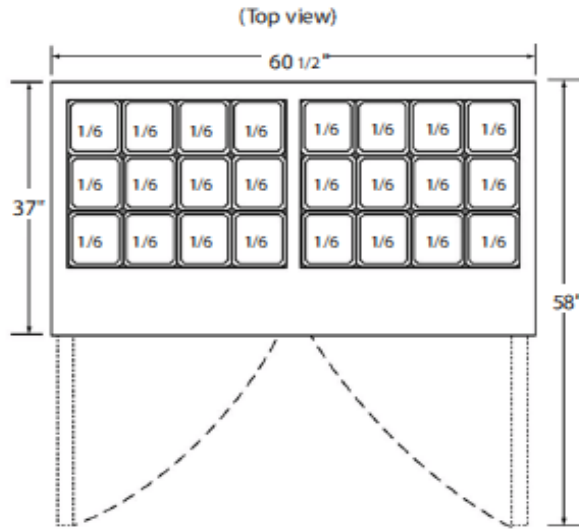
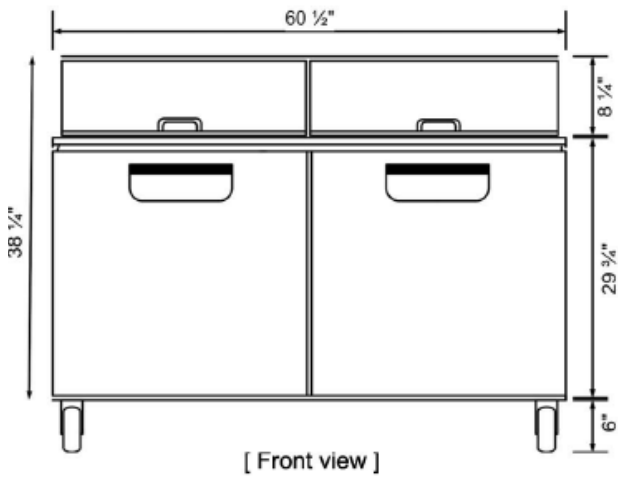

Width	Depth	Height	Crated Weight	Voltage	Hp	Amps	Refrigerant	Cubic ft	Holding Temp
60.4"	33.0"	42.8"	362 LBS	115V/60Hz	3/8	6.0	R134A	16	32°F to 45°F

6890 Distribution Drive



Beltsville, MD 20705 USA